



The Good Seat.™



CATALOG

Ergonomic **33** Marine Seating



MADE IN USA

TOPSIDE PERFORMANCE FOR THE PILOTHOUSE & FLYBRIDGE



STIDD = Superior Technical Innovation . . . from Design to Delivery.



Ask your fellow boaters - they will tell you that STIDD seats make boating more enjoyable! We look forward to welcoming you to the STIDD family.

Celebrating 33 Years of Quality, Innovation & Customer Care.

Since first bringing ergonomic design and engineering to the marine seating field in 1991, STIDD seats have become world-renown for quality, comfort, strength and universal goodness.

As we celebrate thirty-three years, we are proud to raise the bar yet higher as we increase full-rate production of 100% "Made in USA" indestructible 316L Stainless Steel Castings for our Luxury Seating line.

Now "The Good Seat" welcomes the 316L Option to the STIDD Family, along with our unyielding commitment to quality, strength, comfort and service.

As flotillas of happy customers around the globe will tell you, the product that we really sell at STIDD is total customer satisfaction, by providing all of the above benefits, plus cheerful rapid response to customer requests.

So, we dedicate this catalog to YOU, our loyal customers - new and old - and thank you profusely for giving us 33 years of opportunity to excel.

Walter Gezari, CEO

Walter Gezari



On the cover: The Viking 54 Sport Tower boasts seaworthiness and fishability plus luxury appointments which include an array of STIDD seats for comfortable cruising.



Just ask the Piano Man and boat builder - Billy Joel "STIDD seats are the best seats in the house".



Above and top: "Lone Wolf" is a custom British Columbia build and cruises with an array of STIDD seats at the upper helm.

Ergonomics, Comfort, Strength & Excellence

For individuals of all body types, STIDD Systems' Ergonomic Marine Seating provides anatomically correct, comfortable positioning and passive restraint for the functional marine environment, while integrating strong, lightweight, corrosion-proof materials with easy-to-operate, multi-functional adjustment features and dynamic appearance.

Biomechanical research indicates that ergonomically correct positioning and stabilization (EPS) maximizes the alertness and performance of individuals in stressful settings. The revolutionary STIDD Systems seating product line is the direct result of combining the latest EPS data with developments in Human Factors Engineering, Computer Aided Design (CAD) and Computerized Numerically Controlled (CNC) production methods with advanced materials and coatings. Built to MIL Standards using CNC manufacturing techniques and proprietary materials proven to survive the open seas, STIDD seats provide unparalleled strength and corrosion resistance as well as anatomically correct, comfortable positioning for the marine environment.



NEW BOAT TEST VIDEO LINK!

Visit stidd.com to see STIDD seats in action!

photos courtesy of The Viking Yacht Co.



NEW!

DELUXE 316L POLISHED STAINLESS

Transform your boating experience with STIDD's new 316L Stainless Steel Option. Developed and produced exclusively for our most discerning superyacht customers, STIDD is proud to introduce 316L stainless components, available across our full-line of Luxury seating products.

Now you can enjoy the superior corrosion resistant qualities of 316L stainless components and the legendary comfort of STIDD seats for years to come.



STIDD's 316L STAINLESS PACKAGE
IS BACKED BY AN INDUSTRY-LEADING

10-YEAR WARRANTY!



Proudly featuring 100%
American made CRES 316L
alloy polished stainless
steel investment castings
and weldments.

STIDD Polished 316L Stainless Components Include:

- 100% made in USA 316L castings.
- American components manufactured, polished and assembled to the highest quality standards.
- Polished 316L Stainless Cast Arm Hubs
- Polished 316L Stainless Footrest Hangers and Cast Foot Plate.
- Polished 316L Stainless Pedestal Tube, Cast Base & Cast Deck Plate

About Stainless

316L stainless steel is a molybdenum-alloyed steel is the preferred steel for use in marine environments because of its greater resistance to pitting corrosion than other grades of steel without molybdenum. Long specified by marine designers and builders for its durability, corrosion resistance, and strength in salt water exposure, 316L Stainless is classified at the highest CRES (Corrosion Resistance) by classification societies and governments worldwide.

For decades, as industrial supply chains of marine foundry products moved out of the US to cheap labor markets in Asia, it has become increasingly difficult to reliably source highest quality 316L stainless steel castings in the USA at competitive costs...until now.

After years of development and engineering of precision investment castings with a small foundry and metals finisher in the USA. STIDD has succeeded in producing 100% Made in USA polished 316L Stainless Steel castings exclusively for our most discerning customers, and we are now proud to make 316L stainless available across our full-line of Luxury seating products.

Now, you can enjoy the superior corrosion resistant qualities of 100% Made in USA 316L stainless components for the world's most demanding mariners...and they are backed by an **INDUSTRY LEADING 10-YEAR WARRANTY!***

500SH & 500XH DELUXE HIGH BACK ADMIRAL



A trio of STIDD Luxury High Back Admirals with custom upholstery at the helm of "Silver Lining" a 50M Christensen.
Photo by Neil Rabinowitz

500SH & 500XH HIGH BACK

Luxury ADMIRAL

The STIDD Luxury High Back Admiral offers unmatched quality and comfort while complimenting the finest interiors. STIDD's legendary comfort and ergonomic adjustments elevate this seat to an unprecedented level of comfort, and beauty.

Now available in your choice of bright finishes:

- 500NSH Deluxe Polished 316L Stainless Upgrade
- 500NXH Standard Polished Chrome Package

A three-position adjustable headrest is standard on all STIDD high back models.

Order factory direct:
631-477-2400 ext.120
email: sales@stidd.com

stidd.com



MADE IN USA

STIDD LUXURY ADMIRAL STANDARD FEATURES

360° swivel with 45° locking detents, 8-inch fore/aft slide, telescoping pedestal with 8-inch vertical height range, folding footrest, folding armrests and 40° reclining backrest. Choice of colors and pedestal height. All power options available

500XH & 500XL STANDARD POLISHED CHROME PACKAGE

For interior bling choose our Deluxe 17-step Chrome-Over-Aluminum Trim Package which includes:

- Polished Chrome Pedestal,
- Polished Chrome Footrest and Hangers
- Polished Chrome Arm Hubs
- Stainless "Trigonal" Clamp Handles

DELUXE POLISHED 316L STAINLESS UPGRADE

For superior corrosion resistance select our new Deluxe 316 Polished Stainless Trim Group which includes:

- Polished 316L Stainless Steel Pedestal
- 316L Stainless Footrest and Hangers
- 316L Stainless Arm Hubs
- Stainless "Trigonal" Clamp Handles

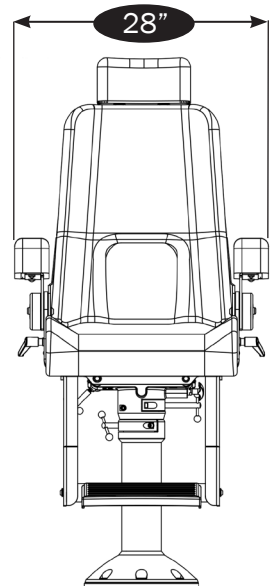

SERIES 500SH & 500XH

The benchmark of seaworthy opulence for the helm or flybridge

DELUXE LOW BACK ADMIRAL 500S & 500XL



Top and below: Two 500XL-2X2s on the flybridge of an Offshore 80 - photos by David Shuler

500S -2X2 Deluxe 316L Stainless Low Back Admiral shown in "Blue Ice" Pumice Ultraleather, RAL1013 powder coat, medium (-2) telescoping pedestal and folding footrest.



ADD THE CONVENIENCE OF MOTORIZED ADJUSTMENTS

A Captain's dream, STIDD's proven power options puts seat adjustments at your finger tips. Our standard power package includes motorized fore/aft and vertical height adjustment without leaving the seat. Never before has a marine seat been so easy to adjust, so comfortable, yet so durable. See page 12 for more information on STIDD power options.

500S & 500XL LOW BACK

Luxury ADMIRAL

Built with the same heritage as our US Coast Guard and military seats, but finished out for gentler pursuits.

Now available in your choice of bright finishes:

- 500S 316L Stainless Trim Group
- 500XL Deluxe Polished Chrome Trim

Order factory direct:
631-477-2400 ext.120
email: sales@stidd.com

stidd.com

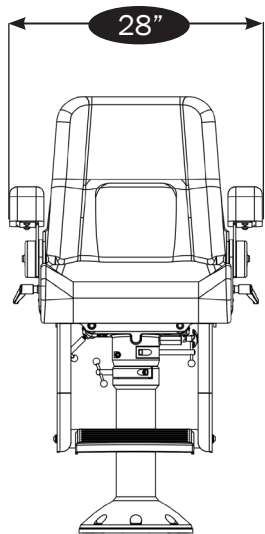

SERIES 500S & 500XL



SERIES 500SH & 500S
• 316L Stainless Upgrade • Net weight: 109 - 112 lbs.
Shipping weight: 126 - 135 lbs.
Ships in two boxes via FedEx or UPS Worldwide.

SERIES 500XH & 500X
• Deluxe Chrome Seat Package • Net weight: 75 - 78 lbs.
Shipping weight: 92 - 102 lbs.
Ships in one box via FedEx or UPS Worldwide.

High Style - Luxurious Comfort

500NSH & 500NXH DELUXE SLIMLINE HIGH BACK ADMIRAL



500NXH-1X2 Deluxe Slimline High Back Admiral shown in "Black" UltraLeather with matching powdercoat frame, tall (-1) telescoping pedestal and folding footrest in deluxe chrome and stainless.



Above: The award winning 49.9m motor yacht 'Ocean Z' built by Heesen in the Netherlands at their Oss shipyard. Her interior is styled by British designer Reymond Langton STIDD Slimline Highbacks at the helm.

500NXH HIGH BACK *Luxury* SLIMLINE

For boats of all sizes, the 500NXH Luxury Slimline offers high-style in a small package. Complete all of STIDD's ergonomic adjustments and features along with a three-position adjustable headrest the 500NXH gives boaters that bucket-seat feel with smart sophisticated styling.

Order factory direct:
631-477-2400 ext. 120
email: sales@stidd.com

stidd.com



A LITTLE ABOUT SLIMLINE SEATS

Our Slimline Series seats are the perfect solution for applications where space is tight. Enjoy all of the comfort and quality of a full-size STIDD seat in less space. Choose from Slimline low back or high back models



in your choice of powdercoat, deluxe chrome, or 316L stainless finishes.

Slimline seats are five inches narrower arm-to-arm than standard Series 500 seats but they are only 1 1/2 inches narrower in seating width

and only 1-inch shallower in seating depth - making them feel just as comfortable as a full-size seat - even for "full-sized" occupants.

*The footrest is 1" higher - conforming to the requirements of our ergonomic database.

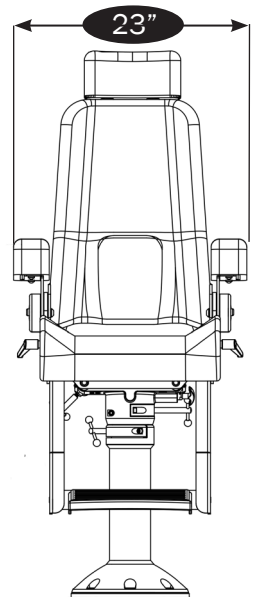

SERIES 500NSH & 500NXH

The right look with the right fit is everything

DELUXE SLIMLINE LOW BACK ADMIRAL 500NS & 500NX



Two 500NX Deluxe Slimline Low Backs shown at the flybridge helm of a Hunt 67, Shown with optional upholstery piping and optional integrated armrests. For more information about incorporating your device into a STIDD armrest see page 15. - photo by Katie Golder



500NS-2X2 Deluxe 316L Stainless Low Back Admiral shown in UltraLeather Coast "Terra" fabric with STIDD Standard Quilting in black thread. STIDD Standard "Midnite Black" powdercoating with medium (-2) telescoping pedestal and folding footrest.

About STIDD

STIDD Systems, Inc. Occupies a 2 acre shipyard with 62,000 square feet of computerized manufacturing facilities, design and administrative offices located on the Greenport, Long Island harbor, approximately 90 statute miles due east of New York City and 16 nautical miles southwest of New London, CT. STIDD Systems' facility has been in continuous use as a shipyard since 1831. In World War I, the shipyard built 60 ft. patrol boats, and during World War II, the yard set Navy production records, delivering 440 136 ft. minesweepers and 1100 landing craft with a labor force of 7500 workers on three shifts.



500NX LOW BACK

Luxury SLIMLINE

They say that good things come in small packages, and that holds true for our 500NX Luxury Slimline model. Just 23-inches wide the 500NX is beautifully finished with deluxe polished chrome accents to provide elegant, durable sparkling compact seating for the pilothouse or flybridge.

Order factory direct:
631-477-2400 ext.120
email: sales@stidd.com

stidd.com

SERIES 500NSH & 500NS

- 316L Stainless Upgrade
 - Net weight: 109 - 112 lbs.
- Shipping weight: 126 - 135 lbs.
Ships in two boxes via FedEx or UPS Worldwide.

SERIES 500NXH & 500NX

- Deluxe Chrome Seat Package
 - Net weight: 75 - 78 lbs.
- Shipping weight: 92 - 102 lbs.
Ships in one box via FedEx or UPS Worldwide.

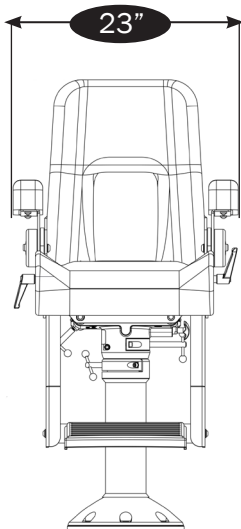

SERIES 500NS & 500NX

STANDARD POLISHED CHROME PACKAGE

For interior bling choose our Deluxe 17-step Chrome-Over-Aluminum Trim Package which includes:

- Polished Chrome Pedestal
- Polished Chrome Footrest and Hangers
- Polished Chrome Arm Hubs
- Stainless "Trigonal" Clamp Handles

DELUXE POLISHED 316L STAINLESS UPGRADE

For superior corrosion resistance select our new Deluxe 316 Polished Stainless Trim Upgrade which includes:

- Polished 316L Stainless Steel Pedestal
- 316L Stainless Footrest and Hangers
- 316L Stainless Arm Hubs
- Stainless "Trigonal" Clamp Handles

All around comfort & strength for commercial or pleasure craft

500-100 POWDERCOATED HIGH BACK ADMIRAL



500-100-1X2 High back Admiral shown with "Black" Naugahyde upholstery, tall telescoping pedestal, standard X2 folding footrest in "Midnite Black" powder coat finish,



Indoors or outdoors STIDD Highbacks are a comfortable choice. Shown above aboard a Magnum 46 Catamaran - photos courtesy Two Oceans Marine

500-100 HIGH BACK ADMIRAL

Comfort & strength for work or play. Outfitted with the same features as our deluxe high backs but finished in tough baked-on powdercoat, Series 500-100 all-purpose high back models fit boats and mariners of every shape and size.

Order factory direct:
631-477-2400 ext. 120
email: sales@stidd.com

stidd.com



The Amazing USCG 47MLB

The U.S. Coast Guards 47-foot Motor Lifeboat (47MLB), is a heavy weather patrol/rescue craft designed to operate in extreme conditions to help save lives. Surpassing search and rescue technologies of the past, the 47MLB operates successfully in such extreme conditions as hurricane-force winds and 20+ foot breaking seas. Along with the ability to safely survive a 360° rollover, the boat can pitch-poll, flipping end over end or roll over in swells and right itself in less than 10 seconds. With a combination of open and enclosed bridge steering stations, the crew's comfort and performance is essential. That's why STIDD Systems' Series 500 Admirals are standard equipment aboard every production 47MLB.

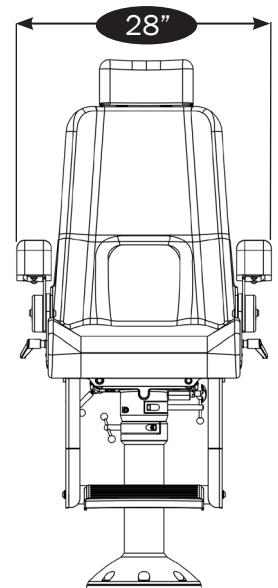

SERIES 500-100

POWDERCOATED LOW BACK ADMIRAL 500-200



Above: Horizon Yachts FD87 is fitted throughout with ingenious amenities which include the spacious helm outfitted with three STIDD Series 500 low backs. - photo courtesy Horizon Yachts.

Right: CL Yachts CLB-72 sports twin STIDD 500-200 full-size Admirals - The Captain's seat is equipped with integrated controls for both Volvo-Penta joystick and Garmin Grid. - photo by Jim Raycroft



500-200-2X2 Low back Admiral shown in "White" UltraLeather upholstery, medium telescoping pedestal, standard X2 folding footrest in "White" powder coat finish,

SERIES 500 STANDARD FEATURES

360° swivel with 45° locking detents, 8-inch fore/aft slide, telescoping pedestal with 8-inch vertical height range, folding footrest, folding armrests and 40° reclining backrest. All power options available



SERIES 500 UPHOLSTERY

All Series 500 seats are available in polyurethane (UltraLeather), vinyl (Naugahyde), factory supplied leather or COM* upholstery packages in your choice of colors.

*COM = Customer's Own Material.

AVAILABLE OPTIONS & ACCESSORIES

- All Power Options:
 - Power Fore/Aft • Power Pedestal
- Upholstery Piping
- Cupholder/Accessory Tray
- Shock-Mitigating Pedestals
- Protective Covers ■ Teak Trim
- Armrest Mounted Controls
- Deck Track Systems
- Seat Belts ■ Writing Surfaces

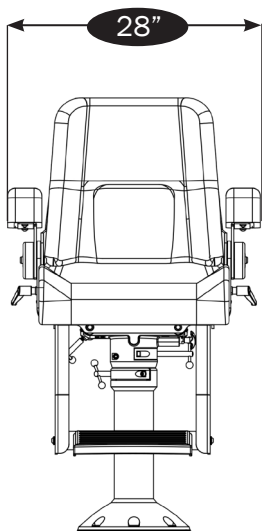

SERIES 500-200

500-200 LOW BACK ADMIRAL

The all-purpose full-size Series 500 low back is finished in tough baked-on powdercoat and comes with STIDD's legendary ergonomic comfort and strength features built in. Choice of colors and pedestal height.

All STIDD 500 Seats are fully-equipped, including fore/aft slides, telescoping pedestal, locking swivel, X2 footrest, deck interface plate, and seat hardware... unless ordered otherwise.

Order factory direct:
631-477-2400 ext.120
email: sales@stidd.com

stidd.com



SERIES 500-100 & 500-200 • Powdercoated Seat Package
Net weight: 75-78 lbs. Shipping weight: 92-102 lbs.
Ships in one box via UPS or FedEx Worldwide

Keeps you snug in rough seas

500NH POWDERCOATED SLIMLINE HIGH BACK



500NH-2X2 High back Slimline Admiral shown in "White" Ultraleather with tall (-2) pedestal and X2 folding footrest in "Hi-Reflectance" White Powdercoat finish.

500NH HIGH BACK SLIMLINE ADMIRAL

Get all of the space-saving Slimline features in a high back configuration. The 500NH powdercoated model is made to work and play as hard as you do. Designed to provide hours of comfort at the helm with the added support of a high backrest complete with three-position adjustable headrest.

Order factory direct:
631-477-2400 ext.120
email: sales@stidd.com

stidd.com



MADE IN USA



Outfitted with our beautiful teak trim package this 57 Shearline stands out on the dock and is super comfortable all the way to the canyon and back.



STIDD makes upgrading a snap!

Shown above: A Slimline high back with our 9" base pedestal makes for an easy installation aboard this Meridian 441 Sedan. Above right: Dual Slimline 500NH-FA Highbacks give this Fairline 65 new level of comfort.

GET COMFORTABLE

Sick and tired of your old seat? STIDD offers mounting solutions for every boat. Retrofitting is easy and our seating experts are ready to assist you on your quest for total comfort.

We have mounting solutions for every make and model. See pages 15, 16 and 17 for more information or simply call our Sales Department to discuss your requirement.

AVAILABLE OPTIONS & ACCESSORIES

- All Power Options:
 - Power Fore/Aft • Power Pedestal
- Upholstery Piping ■ Cupholder/Accessory Tray
- Armrest Mounted Controls ■ Teak Trim ■ Protective Covers
- Deck Track Systems ■ Writing Surfaces
- Shock-Mitigating Pedestals

The best kept secret on the waterfront

POWDERCOATED SLIMLINE LOW BACK **500N**



Cruisers Yachts 60 Cantius features two STIDD Slimline seats - shown in "Sparkle Silver" powdercoat with luxurious UltraLeather upholstery.



500N-2X2 "Slimline Admiral" Low back shown in "White" Ultraleather with medium (-2) Telescoping pedestal and X2 folding footrest in "Hi-Reflectance White" powder coat.



Our sales team is ready to work with you to make "YOUR STIDD". Here's a beautiful Albemarle 36 Express with twin Slimlines ordered with optional teak trim, upholstery piping and custom embroidery.



SERIES 500N UPHOLSTERY
All Series 500 seats are available in polyurethane (Ultraleather), vinyl (Naugahyde), factory supplied leather or COM* upholstery packages in your choice of colors.

*COM - Customer's Own Material

SERIES 500N SLIMLINE STANDARD FEATURES
360° swivel with 45° locking detents, 8" fore/aft slide, telescoping pedestal with 8" vertical height range, folding footrest, folding armrests and 40° reclining backrest. All power options available.

500N LOW BACK **SLIMLINE ADMIRAL**

The all-purpose 500N Slimline low back finished in tough baked-on powdercoat provides all of the durability and comfort of our standard Series 500 in a trim 23" wide package. Inside or out they are versatile enough to fit small boats yet dynamic enough to enhance a large bridge.
Order factory direct:

Order factory direct:
631-477-2400 ext.120
email: sales@stidd.com

stidd.com

SERIES 500NH & 500N • Powdercoated Seat Package
Net weight: 75 - 78 lbs.
Shipping weight: 92 - 102 lbs.
Ships in one box via FedEx or UPS Worldwide.



MADE IN USA

Discover all of the STIDD ergonomic features

STANDARD FEATURES

FOLDING-LOCKING ARMRESTS

Adjustable armrests fold a full 90° and lock in place

WATERPROOF ARMREST LOCK

Push-button lock mechanism releases the armrest to swing away for quick exits and freedom of movement, or locks positively in place to secure the armrest for extra hold-on.

ORTHOPEDIC CONTOURS

STIDD seats are designed to provide orthopedically correct support. The waterfall design of the seat cushion improves circulation to the legs and feet so you can sit comfortably for hours on long transits

360° SWIVEL AND LOCK

STIDD seats rotate a full 360 degrees with spring loaded stainless detent positions at 45° intervals.

X2 FOLDING FOOTREST

Our standard folding footrest folds up so you can lean against the seat cushion when standing. Complete with a rugged ABS tread and stainless "S" logo.

RECLINING BACKREST

Adjust and lock securely in any position over a 40° range. A small adjustment in back angle can provide a big difference in ride comfort.

8-INCH FORE/AFT SLIDE

Move forward for maneuvering or back for cruising or anywhere in between. Nominal 8-inch adjustment range.

VERTICAL HEIGHT ADJUSTMENT

STIDD telescoping pedestals offer an 8-inch range of vertical height adjustment. Equipped with a locking clamp and gas spring counter-balanced for convenient height adjustment.

MASSIVE TELESCOPING PEDESTAL

STIDD's heavy-duty 4-inch diameter aluminum alloy telescoping pedestals provide unsurpassed impact absorption and lateral stability. Choose from standard 12-inch diameter or optional 9-inch diameter bases.



UPHOLSTERY COVERINGS

POLYURETHANE (Ultraleather)

Our most popular upholstery choice, because it is truly the best value! For a warm and rich upholstery covering with the optimal combination of comfort and strength, choose Polyurethane over spun rayon (a marine grade formulation of a fabric commonly referred to as "Ultraleather"). This amazing synthetic leather-like plastic is strong, durable, supple and easy to maintain, which is why it has become the choice of sport fishermen, interior designers and discriminating yacht owners. Available for all models.

VINYL (Naugahyde)

Available in a range of basic colors, this traditional Naugahyde vinyl covering is "industrial strength". Our most economical covering, vinyl is generally used in either interior or exterior places, where extreme comfort is not a primary goal. Available for all models.

C.O.M. & FACTORY-SUPPLIED PREMIUM LEATHER

For those rare individuals in whose vocabulary the words "compromise" and "economize" do not exist, factory-supplied premium leather and customer supplied upholstery options are also available for any STIDD seat. 75 square feet of customer's premium leather is required per seat. If fabric is supplied: 4 yards of 54-inch wide roll stock is recommended. Contact factory for more details. Upholstery up-charge applies to all COM and Leather options.

ADDITIONAL FABRIC YARDAGE

Need matching material to complete your overhead? Additional 54" wide roll stock is available by the yard, up to 33 yds. per roll. Order as many yards as you need!

DECK PLATE NOTES

Standard 12-inch diameter base pedestals ship with a 12-inch diameter cast aluminum deck plate in matching finish, Helicoiled and indexed for foolproof installation, once mounted to your deck, the seat becomes integrally coupled to the boat.

Deck plates must be properly mounted to a secure foundation. Seats should be ordered as early in the construction phase as possible to assure timely delivery of color coordinated deck plates to coincide with the completion of your interior overhead. Please note that positioning the deck plate before mounting is very important and installation times may vary due to vessel characteristics.

PLACEMENT PLANNING

To assist you in planning your seating layout, please consider these helpful hints.

- The center of the deckplate is normally mounted approximately 22-inches aft of the nearest obstruction at knee level. (i.e. steering wheel, bulkhead, etc.)
- Determine the correct mounting location and confirm that you have suitable foundation.
- Install the deck plate with the arrow facing forward and center.
- Attach your seat to the deck plate with the stainless fasteners, isolation gasket and washers provided.
- Installers mounting Power Seats - TAKE EXTRA CARE Do not pinch the wiring!
- Attach a ground wire to one of the deck plate thru-bolts to minimize stray galvanic activity between boat and seat.

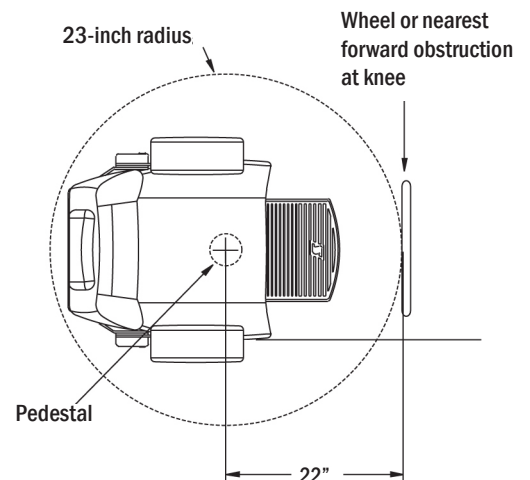

OPTIONS & ACCESSORIES

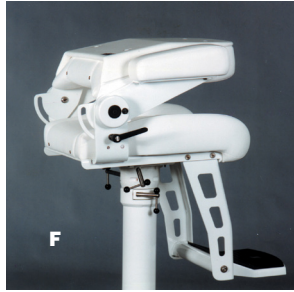

A. TEAK TRIM OPTION

Get the classic sportfish look, without the traditional backache! STIDD's gleaming bright teak package features a teak ladder back; teak armrest hubs and teak foot tread. All hand finished with 10 coats of Epiphanies tongue oil varnish and hand rubbed between coats for a spectacular appearance. 510-118 Teak trim package is available for STIDD 500, 500N and 1200 low back models.

B. CUP HOLDER / ACCESSORY TRAY

Holds your drink and your sunglasses, too. Easy to install and finished in matching powdercoat this fold out cup holder fits either left or right arm. Fits all models, order with your new STIDD seat or retrofit. Order p/n 510-199.

C. ACCENT PIPING

Add flare to any STIDD seat with this optional upholstery trim package #510-124. Combine the colors of your choice for a decorating accent that reflects your personal style. Optional upholstery piping is available for all STIDD models.

D. PROTECTIVE COVERS

Protect your investment with an authentic STIDD cover. The white marine-grade sunbrella looks sharp while protecting your seats when not in use. Embroidered with the STIDD logo, available for all models. Specify full-size or slimline, highback or lowback when ordering.

E. CHART POCKET

Stow your charts, maps, notebooks and favorite reading material right behind your seat. Upholstered in matching seat fabric, this convenient storage pocket features an elastic top, durable contoured ABS backing, and drainage holes. Order with your new STIDD seat or retrofit. Order p/n 510-108

F. SPORTFISH BACK

Available for Series 500 and 500N Low Back models, this forward folding backrest option offers increased visibility and a convenient support to lean against when facing aft. Specify p/n 510-117

G. ACCESSORY BULKHEAD MOUNT FOOTREST

Our X2 folding footrest in a bulkhead mount! For use with box mounted seats. Powdercoat or chrome finish p/n 510-116-B

H. REPLACEMENT CUSHIONS

Make your STIDD look like new again. Order genuine STIDD replacement cushions factory direct. Individual cushions or complete sets are available. Easy do-it-yourself installation. Please provide the serial number from your STIDD seat and call for assistance.

- New cushions come ready to install.
- We do not recover worn cushions – You don't send anything back.
- Replacement cushions are factory replacements made with STIDD's proprietary foam so your STIDD seat will look and FEEL like new!
- Installation is easy. Simply remove the upholstery caps, and remove/install with a Phillips head screwdriver

I. FRENCH SEAM OPTION

This elegant seam technique is now available as an upgrade for all STIDD models.

J. QUILTED CUSHION SET

For an up-scale design element, ask about STIDD's new quilted upholstery option. Our diamond shaped quilting offers a three dimensional texture with a luxury feel

STIDD POWER OPTIONS

A captain's dream, STIDD's proven power option puts seat adjustments at your fingertips. Motorized fore/aft vertical height, and swivel adjustments can be made without leaving the seat. Never before has a marine seat been so easy to adjust, so comfortable, yet so durable. Specify 12VDC (standard) or 24VDC (optional) when placing your order. No exposed wiring - all wiring runs through the pedestal for a neat appearance. All electronic components are completely marinated. Power options are available for all STIDD models.

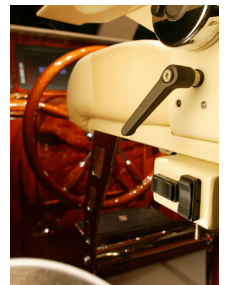

It's showtime! Best seats in a supporting role

SPECIAL EDITION SEATS

You'll be the envy of your fishing buddies and feel like you just filmed an episode of your favorite reality fishing show when you're sitting pretty in one of our new Special Edition, Wicked Tuna or Deadliest Catch models. As seen on: Wicked Tuna, Wicked Tuna Outer Banks, Deadliest Catch and Bloodline, These special edition seats are available in your choice of STIDD Full-Size Admiral or Slimline models. Get yours today. Specify High Back or Low Back at time of order.

Order factory direct:
631-477-2400 ext.120
email: sales@stidd.com

stidd.com

*Embroidery is limited to black or white.

AS SEEN ON



WICKED TUNA



Paul Hebert from Wicked Tuna will tell you "STIDD seats are wicked good!"



Capt Casey McManus filming Deadliest Catch "Bloodline" in Hawaii.



Sean Dwyer of "Brenna A" with Jake Anderson from "Saga"



Above: Freddie working aboard "F/V Wizard".



Captain John Harris and Capt Casey McManus from F/V Cornelia Marie



L. Capt. "Wild Bill" Wichowski from "Cape Caution" with our Pacific Northwest sales rep Keith Mahler.



STIDD Systems is proud to support the captains and crew members of Deadliest Catch

STIDD Systems is proud to support the captains and crew members of Wicked Tuna

- | | |
|------------------|------------------|
| FV-Tuna.com | Dave Carraro |
| Hard Merchandise | Dave Marciano |
| Pinwheel | Tyler McLaughlin |
| Hot Tuna | TJ Ott |
| Wicked Pissah | Paul Hebert |
| Fat Tuna | Bob Cook |
| Moonshine | Spurge Krasowski |

- | | |
|------------------|---------------------|
| Time Bandit | Josh Harris |
| Cornelia Marie | Casey McManus |
| Time Bandit | Jonathan Hillstrand |
| The Northwestern | Sig Hansen |
| Brenna A | Sean Dwyer |
| Saga | Jake Anderson |

Deadliest Catch and Bloodline are American documentary and reality television shows on the Discovery channel. Wicked Tuna and Wicked Tuna Outer Banks are reality series that air on the National Geographic Channel.

Why stand when you can STIDD?

CONTROL ENCLOSURES



OPTIONAL 9-INCH BASE TELESCOPING PEDESTALS

Replacing existing seats? Consider our optional 9-inch diameter pedestals. With a universal 3-bolt mounting pattern these bases mate with most 9-inch deckplates* for easy, economical do-it-yourself installation. Available in powdercoat or chrome finishes in manual or power configurations.

*Fits Pomponette, Murray, Todd and other 9-inch diameter deckplates.

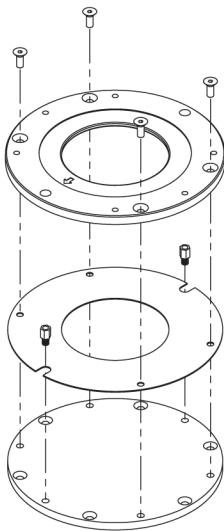

6 BOLT to 8 BOLT DECKPLATE ADAPTER

STIDD Model 510-1-175 Adapter

Attention SeaRay owners... don't drop your headliner... upgrading to a STIDD just got easier! Our new adapter mounts directly to your existing 12-inch 6-bolt deckplate for quick and easy STIDD seat installation.

Available in powdercoat finish only.



Integrated armrests for Volvo-Penta, Garmin Simrad and ZF Controls
510-145 for Garmin Grid (shown above left) 510-200 for Volvo-Penta IPS Joystick (shown above center) 510-130 for Simrad GB50 Quickstick (shown above right)

Consult factory for more information.

JOYSTICK & TRACKBALL ENCLOSURES

Armrest mounted Control Enclosures are available for all STIDD models

Contact us with the make and model of your device. Every enclosure is designed with several biomechanical subtleties, such as proper amount of wrist and forearm internal rotation, flexion, and radial deviation to make the input device comfortable to hold, use and operate on long transits. We have delivered enclosures for the most demanding yacht, military and government applications.

Order factory direct:

631-477-2400 ext.120

email: sales@stidd.com

stidd.com

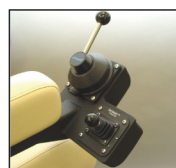

BOX MOUNT SOLUTIONS FIXED SEAT HEIGHT

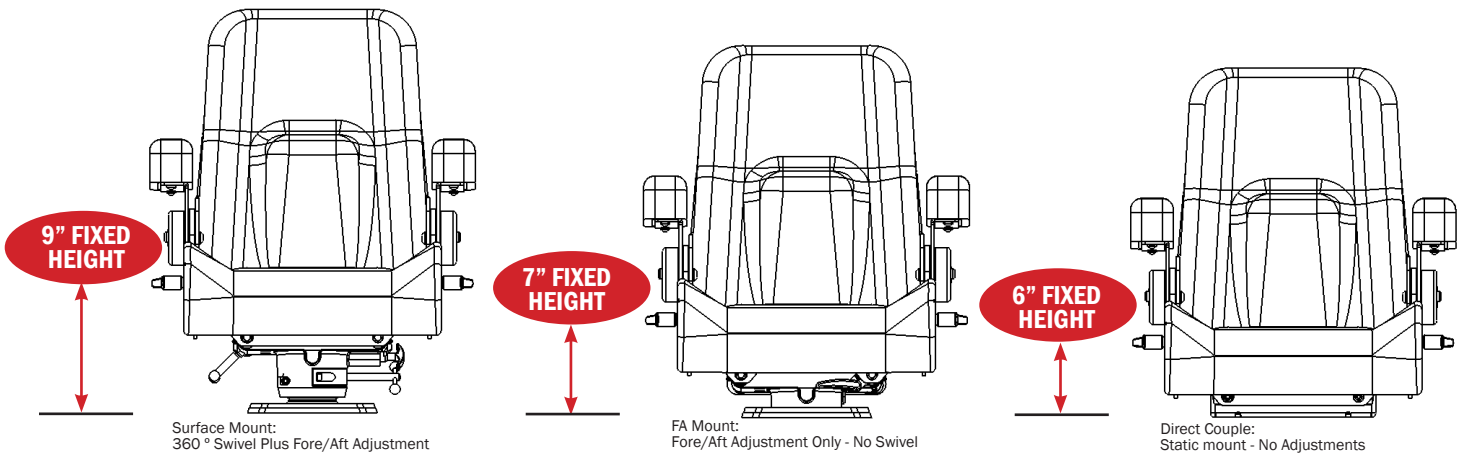

For Fixed Height Seat Applications STIDD has a complete line of mounting solutions.

SURFACE MOUNT

510-1-107-9

Mount any STIDD seat on an existing box or molded structure at the helm with the STIDD surface mount pedestal. Our surface mount pedestal provides a 9-inch fixed seat height, 360 degree swivel, and 8-inch fore/aft adjustment. For Series 500, 500N, 500W and 1200 seats. Accepts manual or power fore/aft equipped seats. Consult factory for available finishes. Ships with a matching deckplate.

FA SERIES

The FA Series is designed for small to mid-sized boats where seats are installed atop storage or fiberglass boxes. The 7-inch fore/aft travel is easily adjusted by releasing the easy-to-reach paddle at the front edge of the seat, plus the front edge of the pedestal is squared off to allow seat positioning closer to the edge of the box or cabinet.

Available for 500N, 500, 500W and 1200 models. Powdercoat finish only. No Swivel.

DIRECT COUPLE

510-1-350

The 570-1-350-direct couple adapter provides a static 6-inch fixed seat height for Series 500, 500N, 500W and 1200 seats. No fore/aft adjustment. Finished in matching powdercoat.



A 43 Sabre Salon Express is shown above with twin STIDD Slimlines with FA mounts. - photo courtesy Sabre Yachts. Top left: Shows a STIDD 1200W bench mounted with Surface Mount Pedestals aboard a 75 foot Fleming. And, a good example of STIDD Flush Mounts is shown below left at the helm of a Coastal Craft yacht . STIDD Accessory Bulkhead footrests are the perfect addition to these mounting solutions. For more information please refer to page 13.

ADJUSTABLE SEAT HEIGHT • BOX MOUNT SOLUTIONS

A comfortable adjustable view



HI-LOW Deck or Box Penetrating Pedestals

For layouts requiring extreme ranges of seat or table height adjustment, STIDD Deck Penetrating pedestals offer the perfect solution. Available for all models, in deluxe chrome or powdercoat finishes. Consult factory with your specific requirements. Available in manual or power.

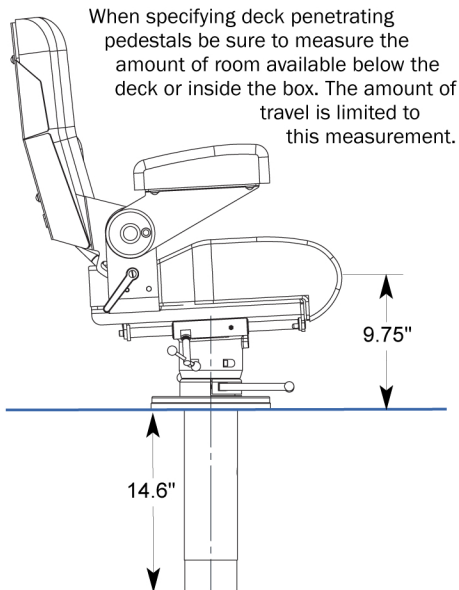

When specifying deck penetrating pedestals be sure to measure the amount of room available below the deck or inside the box. The amount of travel is limited to this measurement.

510-1100-9.75 - 17.75 Deck Penetrating Pedestal

Our most popular deck penetrating pedestal provides an eight inch telescoping seat height range of 9.75" to 17.75" with 14.6" bury. Available for all models. 9" dia. pedestal base.



Cabinet space with a view! Top: Two 500N Slimlines with deck penetrating telescoping pedestals aboard an MJM 34Z. Right: The helm of the Grand Banks 55 Eastbay SX features a deck penetrating pedestal which provides an adjustable seat height for better visibility.



DECK TRACKS

For added mobility at the helm, the STIDD deck track system offers a smooth slide carriage. Simply depress the foot bar and slide the seat forward or backward to the desired position, release and lock. Carriage locks every two inches.

510-V205-T Deck Track System.

Powdercoat finish.
Custom track lengths available.
Consult factory with your requirements.

TABLE PEDESTALS

Telescoping Table Pedestals are available in many styles and sizes, manual and power. Consult factory.

Select the telescoping pedestal that best suits your table height requirements, in either manual or power.

-1 Tall telescoping pedestal
(31-39" Seat Height Range)
(25-33" Table Height Range)

-2 Medium telescoping pedestal
(26-34" Seat Height Range)
(20-28" Table Height Range)



EXPEDITION TRAY

Model 510-121

Surf the internet, eat lunch, or finally get down to writing your memoirs in the comfort of your STIDD seat, with STIDD's new "Expedition Tray" This clever accessory table is perfect for mariners who need a stable surface for a laptop, a mouse, or for just kicking back and enjoying a snack. You'll find dozens of convenient uses for it. The "Expedition Tray" easily folds out and locks in place, or folds up and stows with the efficient, smart operation that is a hallmark of all STIDD designs. Available for Standard Series 500 and 500N Slimline Seats. For new STIDD seat orders. Powdercoat finish only.

Strong, roomy and so comfortable!

500W 36-INCH WIDE LOW BACK ADMIRAL



500W • WIDE •

Here's the perfect seat for boat owners who need some extra room. At 36 inches wide the 500W is a full 8 inches wider than standard Series 500 models and 13 inches wider than Slimline seats. Choose from tough baked-on powdercoat or deluxe polished chrome finishes in your choice of upholstery.

500W seats are available with all Series 500 options. Choose power, piping, chrome, surface mounts or deck penetrating pedestals... no matter how you outfit it's the best seat in the house.

AVAILABLE OPTIONS & ACCESSORIES

- Deluxe Chrome & Stainless Package
- Power Fore/Aft & Power Pedestal
- Armrest Mounted Controls
- Deck Track Systems ■ Upholstery Piping
- Cupholder/Accessory Tray
- Protective Covers ■ Teak Trim

Order factory direct:

631-477-2400 ext.120
email: sales@stidd.com

stidd.com



Top: Twin 500Ws with adjustable deck penetrating pedestals are standard equipment on the MJM 40Z Downeast. Photo by Billy Black - courtesy MJM Yachts.

Above: 500WX-2x2 with the Deluxe Chrome Package at the starboard helm of a 76 Nordhavn.

Above right: Equipped with power fore-aft and power pedestal the STIDD 500W makes getting comfortable easy! Shown here aboard a Tiara 43 Open.



SERIES 500W

Net weight: 86 - 93 lbs.
Shipping weight: 105 - 115 lbs.
(Manual powdercoated packages)
Call for Chrome and Power weights.
Ships in complete in one box
Oversized package
40 X 38 X 24.

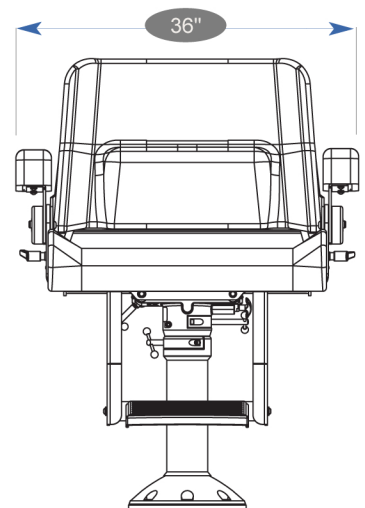

SERIES 500W

DOUBLE SEATS 1200 & 1200W

Side by Side Comfort



Whether your boating off the coast of France or navigating the Intercoastal waterway STIDD bench seats offer a comfortable seating solution for two. Series 1200W shown above aboard a Wajer 38S and a Series 1200 shown below on the flybridge of a Fleming 58.

1200 & 1200W DOUBLE SEATTEES

For side-by-side seating, STIDD Series 1200 Double Seats are the most accommodating seats you can buy. Select from premium chrome & stainless or powdercoat finishes in two models:

Series 1200: 45-inches wide or
Series 1200W: 54-inches wide.

SERIES 1200 STANDARD FEATURES

8-inch fore/aft slides, twin telescoping pedestals with 8-inch vertical height range, individual folding footrests, folding armrests and one-piece 40° reclining backrest. Power options available. 1200W models include a removable center armrest. Consult page 16 and 17 for box mount options

Order factory direct:

631-477-2400 ext.120
email: sales@stidd.com

stidd.com.

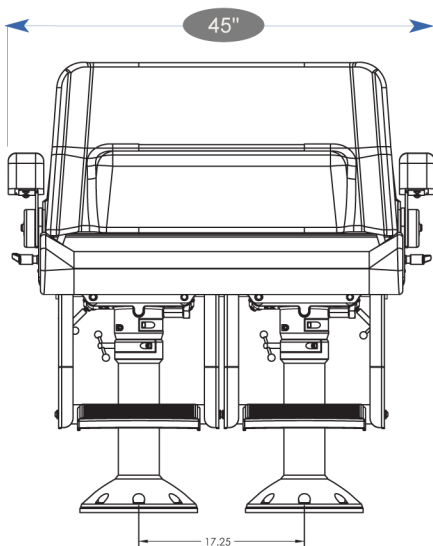

SERIES 1200

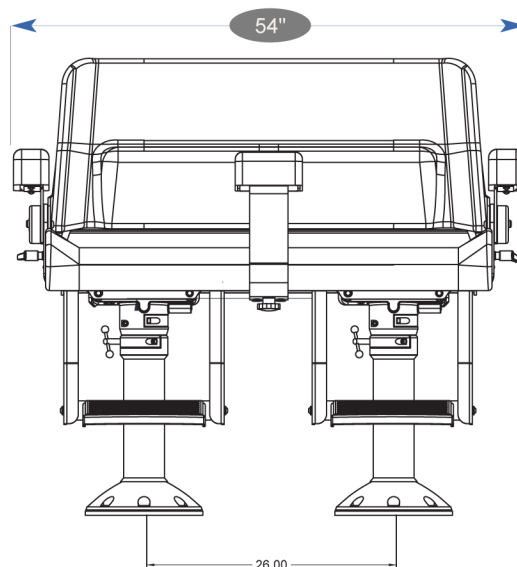

SERIES 1200W

SERIES 1200 - 1200W

Net weight: 145 - 165 lbs.

(Manual powdercoated packages)

Call for Chrome and Power weights.

Ships assembled / crated

Crate: 60 x 36 X 54

STIDD WINS NAVY LCS & CDS SEAT CONTRACTS



**ATTENTION
GOVERNMENT
BUYERS**

NEW!

SPECIAL PURPOSE CHAIR:

Model 500N-7QR-CDS-2 (NSN 2090-01-606-2405), is the DLA and USN approved equivalent to Turnbull's "Chair, Pedestal, Shipboard" (NSN 2090-00-814-1101) and conveniently attaches to any existing "Plate, Mounting" (NSN 5340014767468).



NEW!
500-100-BW

BRIDGE WING CHAIR:

STIDD Model 500-100-BW

fits onto the welded pipe stanchion of, and is a direct replacement for Turnbull's "Chair, Shipboard Bridge Wing" (NSN 2090-00-368-4788)

All STIDD Military Seats are available in your choice of STIDD finishes, fabrics and colors. For further information, contact sales@stidd.com



The LCS Freedom variant team led by Lockheed Martin



The LCS Independence variant team led by General Dynamics and Austal USA

STIDD Systems, Inc. is proud to support the US Navy LCS (Littoral Combat Ship) program - with seats aboard both LCS variants. The Littoral Combat Ship (LCS) class is a fast, agile, focused-mission platform designed for operation in near-shore environments yet capable of open-ocean operation.

STIDD has been selected to provide the Bridge seating for both variants of the cutting edge US Navy LCS (Littoral Combat Ship) program and is also provides the standard seating for the CDS (Common Display System) program, which provides standardized interchangeable systems for all classes of US Navy Ships.



With direct replacements for numerous existing shipboard legacy NSNs, STIDD is committed to updating the aging WWII Era seating aboard US Navy ships by providing biomechanically correct seating with unsurpassed quality and comfort imbedded into every STIDD product.



800V53 ADVANCED SHOCK-MITIGATING SEAT BOLSTER

The 800V53 offers a solution to repetitive orthopedic stress injuries resulting from violent slam loads. Proven in 6 ft. seas at 50 knots aboard the MkV Special Operations Craft, the 800V53 provides superior comfort and safety for operators in long-duration, open-water transits.

800V53 STANDARD FEATURES

- 7" Vertical Stroke Shock Absorber
- 30° Reclining Backrest with lumbar and thoracic support and massive headrest
- Quickly converts to standing position
- Forearm supports with "Stealth" hand grips
- Corrosion Resistant Stainless CRES Lap Belt
- Ergonomic Mission- configurable variable rate physiological foam cushions
- Hi-Tenacity polyester upholstery
- Fold-away Locking Reinforced Armrests
- Fold-away Stainless Footrest
- Rear Passenger Grab Bar
- Welded Aluminum Alloy Structure
- Non-corrosive components
- Modular frame construction for single or double seat configurations.
- Consult factory for more information.



STIDD 800v53 seats - proven aboard the 82 ft. USSOCOM MkV SOC Special Operations high-performance combatant craft.

500V5 SHOCK-MITIGATING PEDESTAL SEATS



Above: USCG 500V5 shown in D/A aluminum finish, hi-tenacity polyester fabric, reinforced armrests and CRES Reel Harness

Top: Two shock-mitigating 500N Slimlines aboard Protector 30 Targa - Photo courtesy Protector Boats.
 Above: 500V5 Shock mitigating seats are standard equipment on every USCG RB-M.
 Left: STIDD V5 Shock-Mitigating pedestals are now available with a space-saving 9-inch diameter base.

V5 SHOCK-MITIGATING PEDESTALS

- Combines all the comfort features of Series 500 and Series 500N Slimline seats with STIDD's proven second-generation shock absorber technology - originally developed for military users.
- Mitigates slam loads associated with high-speed transits in sea state 3-4 to comfortable levels.
- 6 5/8-inch diameter pedestal provides 4-inches of nitrogen-diaphragm shock travel to soften impacts.
- Rated for occupants weighing up to 350 lbs.
- 10-position adjustable rebound damping.
- Factory pre-set spring pre-load.
- Powdercoat or D/A finish only
- Available in 6 configurations providing initial seat heights from 28-inches to 36-inches.
- Consult factory with your requirements.



STIDD V5 Shock-Mitigating pedestals are available in six height configurations for a perfect fit.

500NH-V5 shown in Hi-Reflectance White powdercoat with "White" UltraLeather upholstery with optional lap belt.

SERIES 500V5 SHOCK-MITIGATING PEDESTAL SEATS

Proven by the United States Coast Guard aboard the 47MLB, the Series 500V5 represents the most advance shock mitigating pedestal seat system available for the marine environment.

The massive 6 5/8 inch diameter pedestal houses a nitrogen diaphragm shock to mitigate slam loads associated with high speed transits in sea state 3-4.

Available for Series 500 or 500N Slimline models

Consult factory for specifications and delivery



SERIES 500 & 1200

Series 1200

1200-1x2

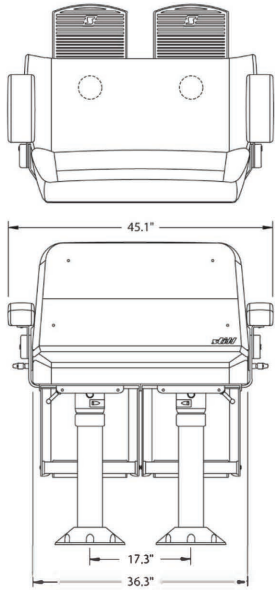

For 1200-2X2 or 1200W-2X2 use height dimensions of 500-200-2X2

1200W-1x2

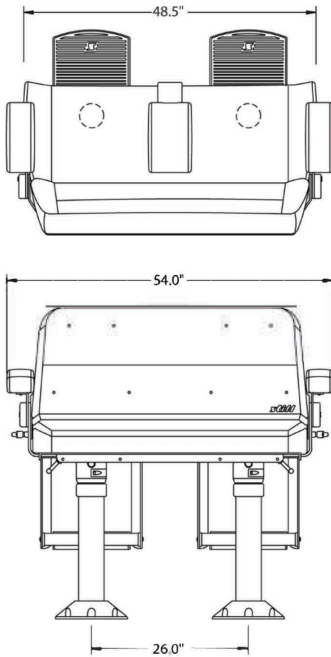

Series 1200 net weight approx: 168 lbs.
 Series 1200W net weight approx: 185 lbs.
 Series 1200 seats ship fully assembled -crated (60x36x54) via Freight Worldwide approx 325 lbs.

DIMENSIONS

All dimensions are in inches. All seats are shown in full aft position.

500XL & 500-200 Low Back

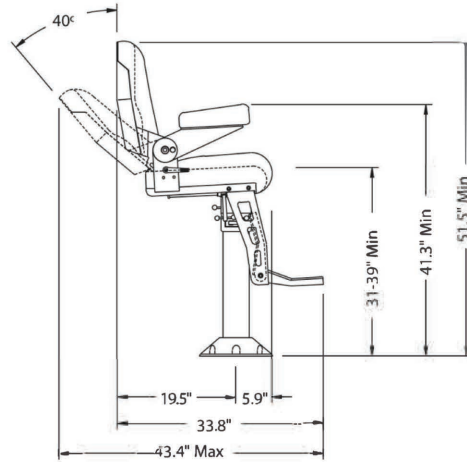

500XL-1X2 & 500-200-1X2

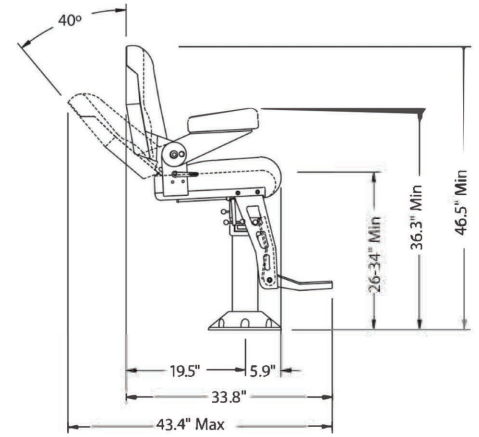

500XL-2X2 & 500-200-2X2

Series 500

All STIDD 500 Seats are fully-equipped, including fore/aft slides, telescoping pedestal, locking swivel, X2 footrest, deck interface plate, and seat hardware...unless ordered otherwise!

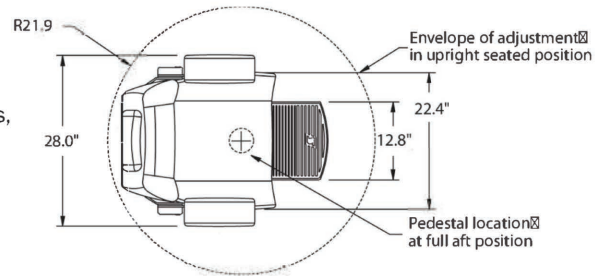

500XH & 500-100 High Back

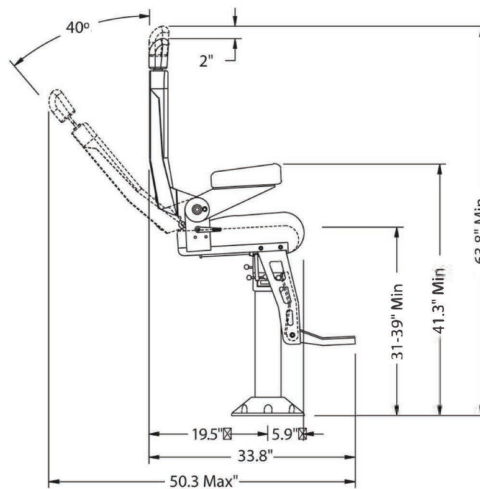

500XH-1X2 & 500-100-1X2

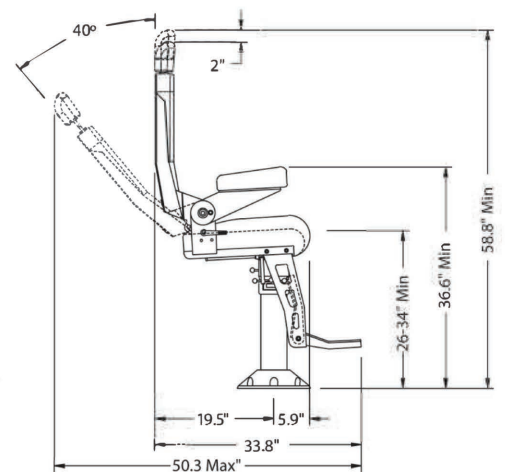

500XH-2X2 & 500-100-2X2

STIDD Systems, Inc. is proud to support these Government Commands including U.S. Special Operations Command



U.S. Coast Guard



U.S. Navy



U.S. Marines



Naval Special Warfare



United States Customs Service



U.S. Army Corps of Engineers

DIMENSIONS

All dimensions are in inches. All seats are shown in full aft position.

500NX & 500N Low Back

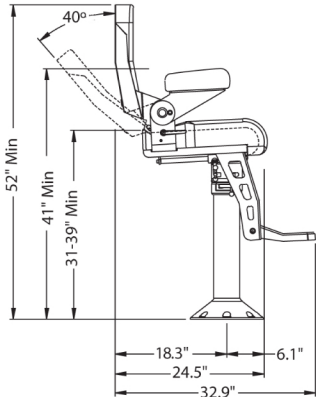

500NX-1X2 & 500N-1X2

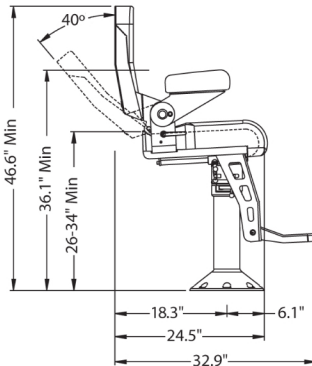

500NX-2X2 & 500N-2X2

Series 500N

All STIDD 500N Seats are fully-equipped, including fore/aft slides, telescoping pedestal, locking swivel, X2 footrest, deck interface plate, and seat hardware...unless ordered otherwise!

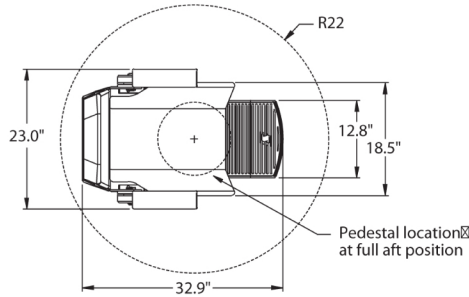

500NHX & 500NH High Back

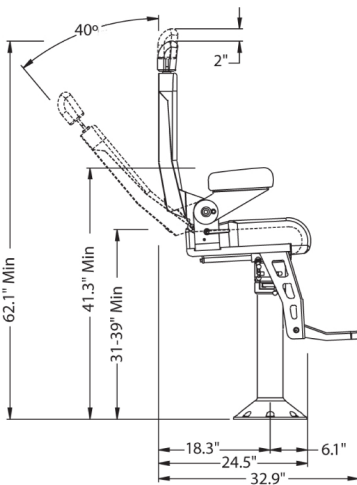

500NHX-1X2 & 500NH-1X2

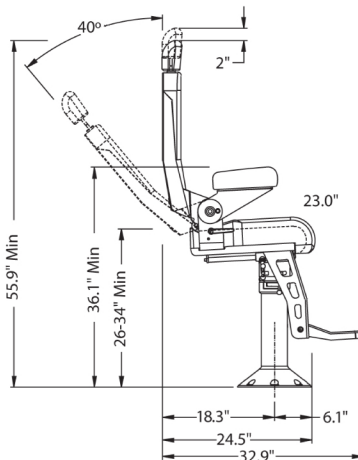

500NHX-2X2 & 500NH-2X2



Canadian Coast Guard



Type Approval Certificate F-15877



ASNE



Member of the Super Yacht Society



STIDD Series 500 Seats are NMMA Certified

Seatless in Seattle?

If you're in the Pacific Northwest, you're in "Mahler Territory". For over two decades, Keith Mahler of Mahler & Associates, Seattle WA, has been selling the finest names in marine equipment such as Kahlenberg, Nautical Structures, Headhunter, Water Desalination and of course, STIDD. We proudly salute Keith Mahler for his hard work, good humor, and professional dedication to his customers' every need. Keith is why you'll never be "Seatless In Seattle". Call Keith at 206-365-3800 or email: keith@mahlerinc.com



He's now a Downeaster!

For personal service in the New England



region, call Tim Loftus at (207) 270-9505. Tim has been selling STIDD seats for over ten years and recently relocated to Maine from the Midwest. He will be happy to assist you with your seat decisions - big or small and will help make sure that you

are boating in comfort and style from Newport to Bar Harbor.

Seatless anywhere else?

ORDER FACTORY DIRECT
631-477-2400 ext 120



email:

sales@stidd.com

STIDD SEATS MEET OR EXCEED THE FOLLOWING SPECIFICATION STANDARDS:

- IMO HSC Code Class II
- USSOCOM MkV SOC Specification
- MIL-STD-1472D
- Navy Shipboard Furniture catalog Listed
- MIL-STD-16230
- US Coast Guard 47MLB Specifications
- Canadian Coast Guard MLB Specifications
- Mark Lavin Memorial Safety Foundation
- RRC/ERC Guidelines
- Det Norske Veritas
- Other Classification authority approvals pending

U.S. Patents: 5,171,063; 5,458,399; 5,463,972; Des. 336,791. Other patents Issued and pending.

Congratulations . . .

You're finally ready to buy a STIDD seat!

Now, it's time to order the best marine seat in the world! Just follow these easy ordering steps and join the thousands of satisfied mariners for every way-point on the globe who have purchased STIDD Systems' fabulous Ergonomic Marine Seats.

EASY ORDERING GUIDE

The moment of truth

STEP 1: SELECT A SEAT SERIES

- SERIES 500 28" WIDE
- SERIES 500N SLIMLINE 23" WIDE
- SERIES 500W 36" WIDE SINGLE
- SERIES 1200 45" WIDE DOUBLE BENCH
- SERIES 1200W 54" WIDE

STEP 2: SELECT SEAT BACK

- LOW BACK
- HIGH BACK

Series 500W & 1200 Seats are available in Low Back only

STEP 3: SELECT FINISH*

- 316L POLISHED STAINLESS STEEL
- DELUXE CHROME & STAINLESS

Please note: On STIDD Deluxe 316L Stainless or Chrome packages the seat frame components are powder coated. Please consult factory for standard powder coat colors. Optional powder coat colors are available at an additional charge.

- POWDER COAT

STEP 4: SELECT UPHOLSTERY**

- VINYL (Naugahyde)
- POLYURETHANE (UltraLeather)
- FACTORY SUPPLIED LEATHER
- C.O.M. (Customer Supplied Material)

STEP 5: SELECT SEAT HEIGHT***

To select the proper seat height range (SHR) measure from the deck to the seating surface. Pedestals are telescoping and provide the following Seat Height Ranges.

TELESCOPING PEDESTALS:

- [-1] Tall 31-39" SHR
- [-2] Medium 26-34" SHR
- [-3] Low 19-23" SHR
- [-5] Low 21- 28" SHR
- Deck Penetrating Consult Factory

BOX MOUNT PEDESTALS:

- Surface Mount 9" fixed seat height allows for swivel and fore/aft
- FA Series 7" fixed seat height fore/aft adjustment. no swivel.
- Direct Couple static 6" fixed seat height, no fore/aft, no swivel

SHOCK MITIGATING:

- Consult Factory

All STIDD Seats are fully-equipped, including fore/aft slides, telescoping pedestal, locking swivel, X2 footrest, deck interface plate, and seat hardware...unless ordered otherwise.

* Keep in mind that no matter which level of finish you choose, some or all of the seat components will be powdercoated to match your upholstery color. Even on the Deluxe Chrome seats, some frame parts are powdercoated to coordinate with your fabric color selection.

** Your upholstery fabric and color selections do not have to be fully decided before ordering, since you normally have a few weeks to finalize while your order enters the production cycle.

*** All pedestals are telescoping (either manual or motorized) with an 8-inch range of adjustment. The "seat height range" (SHR) is a phrase used to help you determine which pedestal to select. The initial seat height is measured from the deck to the surface of the seat cushion where your butt hits the seat in the lowest (down) position. NOTE: Selecting the proper pedestal is one of the most important aspects of your new seat order. Pedestals are complex mechanical assemblies and cannot be "cut down" (like other manufacturers' seats) if you choose the wrong size. Your pedestal decision does not have to be made before ordering (you normally have a few weeks to finalize while your order enters the production cycle), but please try to measure and plan your installation carefully.

STEP 6: SELECT ADJUSTMENT

- MANUAL
- 12VDC POWER 24VDC POWER

STEP 7: SELECT OPTIONS

- Bright Teak Trim Group
- Armrest Control Enclosure
- 510-124 Piping on Cushion Set
- Fitted Protective Cover
- 510-199 Cupholder/Accessory Tray
- 510-108 Chart Pocket
- 510-112 Additional cut yardage UltraLeather. Specify amount.
- 510-110 CRES Seat Belt
- Other _____

STEP 8: SHIPPING

- STANDARD GROUND SHIPPING
- EXPEDITED
- Overnight 2nd Day 3rd Day
- INTERNATIONAL
- OTHER

STEP 9: PAYMENT

- CREDIT CARD
- CHECK
- WIRE TRANSFER

STEP 10: PLACE YOUR ORDER

Call: 631-477-2400 (Option 1)

Fax: 631-477-1095

email: sales@stidd.com

If you have additional questions or require a color chart, please call or email us and our team of seat experts will assist you.

stidd.com

Prices, specifications and availability of all STIDD Systems, Inc. products are subject to change without notice.

ORDERING INFORMATION & PAYMENT TERMS:

Please note our payment terms. PAYMENT IN FULL is required for ALL ACCOUNTS before your order is entered into production. All prices are in U.S. dollars, payable via credit card, check or wire transfer. Wire transfer information is available upon request. Please note that checks drawn on a foreign bank will not be accepted.



All major credit cards accepted

Shipping: All orders are shipped F.O.B. Greenport, NY USA via FedEx or UPS. Customer pays all shipping charges. Shipping on customer's account is also available.

International Shipping: Shipping charges & insurance prepaid to destination. Customer pays all duties, taxes & brokerage fees, etc. COLLECT. Shipping via customer's selected freight forwarder is available. Contact STIDD Shipping Dept. for pick-up hours and directions to STIDD factory.

CUSTOMER SERVICE & SUPPORT

Last but not least, the only product we actually sell at STIDD Systems is Customer Satisfaction. This means that Customer Service and Support is our highest priority. More than just words on a page, STIDD's unparalleled Customer Service means prompt personal attention to your every need. Every member of our staff helps to make your STIDD Seat experience totally satisfying. We look forward to welcoming you aboard for years of style, safety, and comfort at sea.

email: CustomerService@stidd.com



STIDD Systems, Inc.

P.O. Box 87 • 220 Carpenter Street
Greenport, NY 11944

631-477-2400 • fax: 631-477-1095

www.stidd.com

REV 10/24