

10. Seat Positioning and Shock Absorber Operation

The 500 Series Version 5 Shock-Mitigating Pedestal represents state of the art shock- mitigation for the marine environment.

To fully benefit from the shock-mitigating seating:

- The seat should be centered over the pedestal (mid-fore/aft position).
- The occupant should sit upright with feet positioned on the footrest.
- Adjust and use the seatbelt/harness.
- Adjust the seatback for comfort and all handles tightened while the vessel is underway.

Note: Leaving the seatback in the fully reclined position while the vessel is underway could cause damage to the seat.

- The spring preload is pre-set at the factory at the optimum level determined in operational tests.
- Rebound damping (upward) speed is adjusted using the knob on the lower back of the pedestal. There are 10 positions available. Turning the knob fully counter clockwise (1) will give the fastest recovery to full stroke between shocks; turning the knob fully clockwise (10) will give the slowest response time.

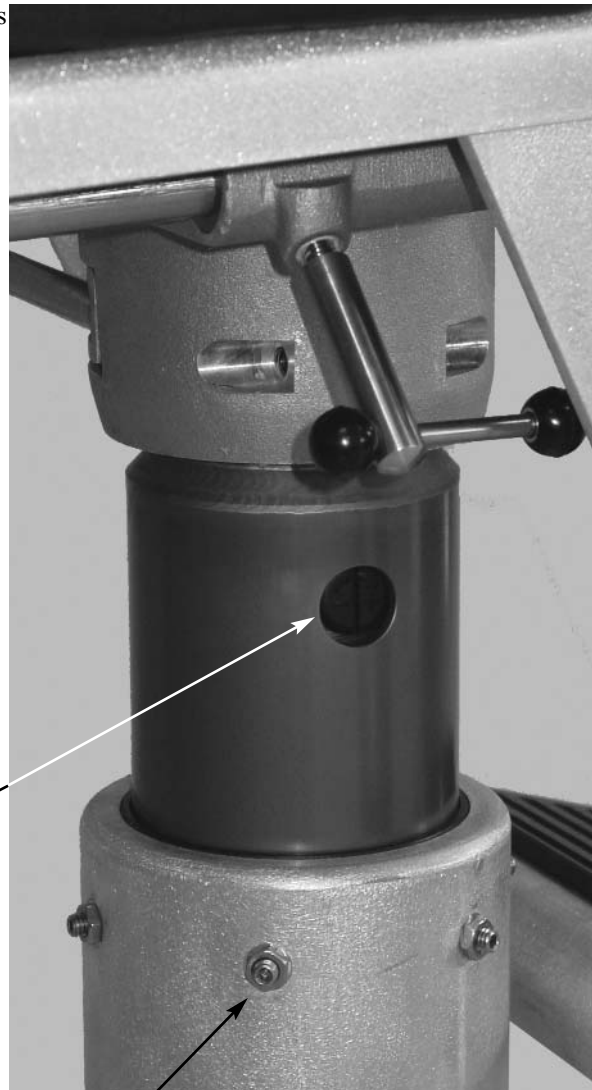

UPPER
ADJUSTMENT
SCREWS
(QTY: 6)



**10 POSITION REBOUND
ADJUSTMENT**
Position 1 = Fully counter clockwise
 (fastest response time)
Position 10 = Fully clockwise
 (slowest response time)



12. General Pedestal Maintenance

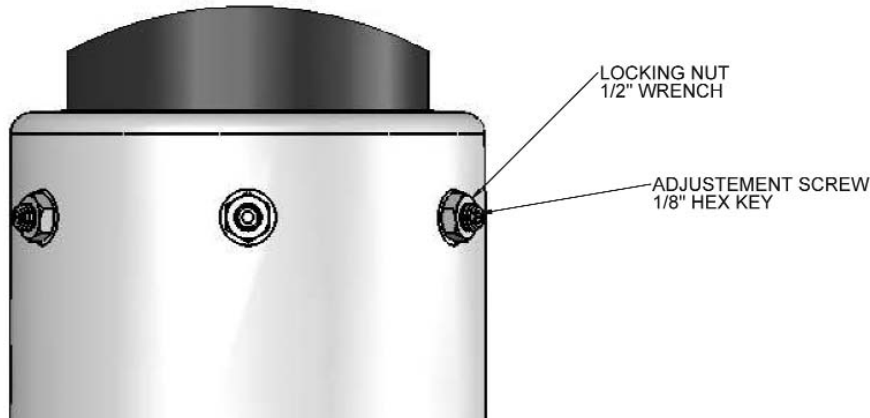

Note: Adjustment of the V5 Pedestal bushing should be done when a considerable amount of play or movement is present between the inner tube and the pedestal.

ADJUSTMENT OF THE BUSHINGS

1. Using a 1/8 in. hex key, hold the adjustment screw from turning while loosening the lock nut on each of the 12 screws with a 1/2 in. wrench.
2. Turn each screw clockwise 1/12th of a turn. (Ex. 12 O'clock to 1 O'clock).
Turn all 12 screws before continuing to Step 3.
3. Rock the seat port/starboard and fore/aft to check for movement.
A small amount of movement is acceptable.
DO NOT OVERTIGHTEN.
Overtightening the bushings will result in poor shock-mitigation, damage to the pedestal, or injury to the passenger.
4. If the pedestal still has an excessive amount of movement, repeat Steps 2 & 3.
5. If the pedestal seems to be too tight and/or the shock motion is stiff and sluggish, turn every screw counter-clockwise 1/12 of a turn and repeat Step 3.
6. A properly adjusted pedestal will slide up and down smoothly. A small amount of port/starboard or fore/aft movement will not affect the pedestal's performance.
7. Use the hex key to hold the adjustment screws while tightening the lock nuts. **DO NOT OVER TIGHTEN** the lock nuts. Only tighten the lock nuts enough to prevent the adjustment screws from working loose over time.

